

**REXA**  
**Xpac**



## L series Linear Actuators

*The Final Step  
to Process Control*

Made in the U.S.A.  
ISO 9001-2000 Certified

Bulletin XLS4, 7/02

# Electraulic™ Actuators & Drives

Manufactured by Koso America

- » 100% modulating duty cycle
- » Deadband is user selectable from 0.05% to 5%
- » Positioning accuracy to 0.15%
- » Input Signal: 4-20 mA analog or pulses
- » Static or dynamic friction has no effect on operation
- » Optional spring failure upon power loss
- » Self-contained, single unit design
- » Microprocessor controlled for reliability and flexibility
- » Discrete operation: Motor only operates when motion is required



**R**EXA Xpac actuators feature a self-contained Electraulic™ power module utilizing the patented Flow Match System. This technology allows precise positioning independent of load variation and locks the cylinder in place when no movement is required. Hydraulic flow is generated by an internal positive displacement gear pump driven by a continuous duty motor without limitations on start, stop, or reverse cycles.

Power modules are available in B, C, ¼D, ½D and D sizes. The difference between the sizes is the maximum flow rate of the hydraulic oil and thus the maximum stroking speed for an actuator. Size C and ¼D have three times the capacity of a B; the ½D has six times the capacity of a B; and the D size has twelve times the capacity of a B. Greater speeds can be obtained by using a manifold containing multiple modules or REXA's unique Booster Pump system. This approach to product configuration offers a high degree of commonality and reduces spare parts inventory. The required stroking speed for an application determines the size and quantity of the modules. Regardless of the selected power module, the rated thrust remains unchanged for any given cylinder size.

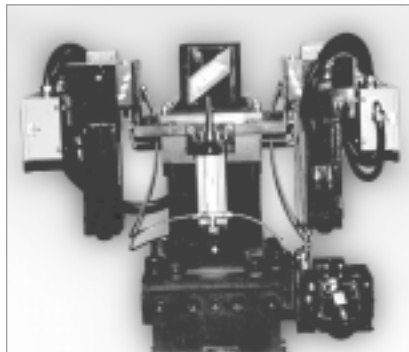

The L series actuator is designed by combining a linear cylinder and the power modules. Rated thrusts from 2 000 lb to 120 000 lb and strokes up to 22 inches are standard. Adaptation to the driven device is usually accomplished by a bolted yoke consisting of two legs and a base. Stem connection is through REXA's load-indicating elastic coupling.

The word Electraulic™ was coined by REXA to describe our revolutionary technology which combines the simplicity of electric operation, the power of hydraulics, the reliability of solid state electronics and the flexibility of user configured control. A hydraulic system has long been recognized as providing superior performance in the operation of final control elements. Unfortunately, advantages such as quick response, precision and high stiffness were often outweighed by frequent maintenance, nonstandard construction and high cost. By utilizing Electraulic technology, REXA is able to bring to general process control the advantages of hydraulic operation without its drawbacks. Self-contained actuator-mounted hydraulics, no maintenance, low power consumption and rugged building block components are inherent in REXA's proven design.

The foundation of Electraulic technology is the Flow Match System, a patented breakthrough in fluidic circuitry. Motor oil, driven by a continuous duty motor and gear pump, is transferred through the Flow Match Valves (FMV) from one side of a double acting cylinder to the other. Variations in magnitude and direction of the load have no effect upon operation. When position is reached the motor shuts off and the FMVs lock the actuator in place. For the complete story, request the publication *Theory of Operation*.

## THE POSITION CONTROL PROCESSOR

### MENU CALIBRATION FOR UNEQUALLED CONTROL OF THE DRIVEN DEVICE

The Xpac is operated by a dedicated microprocessor, the Position Control Processor (PCP). Contained within the control enclosure, the PCP has three modes of operation: *Automatic*, *Setup* and *Local*. For modulating operation, the PCP is in the *Automatic* Mode and functions much like a conventional positioner. The control signal and actuator's position (indicated on a 5 digit display) are continually compared to each other. If the difference between these values is greater than the selected deadband, then the motor is rotated in the required direction until the new position is reached. Response to a change in control signal is immediate.

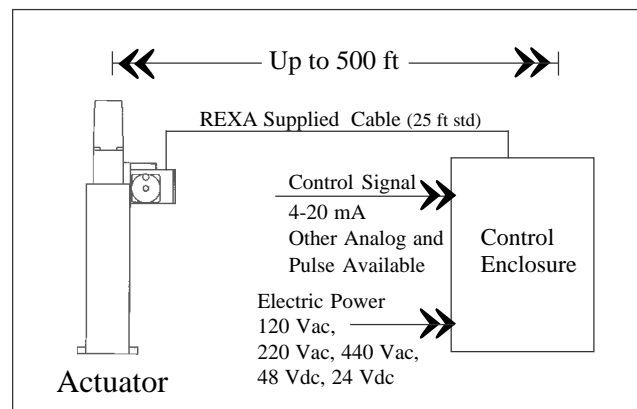

The PCP is calibrated in the *Setup* mode by a simple routine which provides the user complete control over actuator operating parameters. Speed, stroke, deadband and control signal can be configured into the PCP by using a three button keypad and the display. This menu-driven *Setup* eliminates the time consuming and often difficult procedures associated with limit switches and potentiometers. Programmed parameters are retained in a permanent memory. For unusual or difficult applications, more sophisticated control capabilities such as flow characterization and water hammer suppression (two speed) are available. Access to the *Setup* mode can be restricted by a passcode.

*Local* allows stroking of the Xpac from the keypad on the PCP. The display will indicate actuator position. The current control signal and last encountered error can also be shown.

**PERFORMANCE SPECIFICATIONS**

**Strokes:** Standard lengths up to 22 inches  
**Output:** 2 000 lb to 120 000 lb<sup>1</sup> (8 895 N-533 787 N)  
 - listing on back page

*Greater thrusts and strokes are available.*

**Deadband:** 0.1% (STD), 0.05% (OPT) Selectable at the PCP between 0.1% and 5.0% of calibrated signal span.

**Positioning Accuracy (RSS)<sup>2</sup>:** <0.15% of full stroke

Linearity (BSL)<sup>2</sup>: <0.05% of full stroke

Repeatability<sup>3</sup>: <0.10% of full stroke

*Please refer to TM3 - Accuracy*

**Stroking Speed:** Adjustable at PCP.

*See back page for Stroke Rates.*

**Response (corner Frequency):**

1.5 Hz for B & C size power modules.

>5 Hz for ¼D, ½D, & D size power modules.

**Failure Mode:** Selectable by user on loss of signal.

Standard is fail in place on loss of power.

<sup>1</sup>Output values are for fail in place actuators. Depending upon the direction of motion, the optional spring failure will increase or decrease the shaft output.

<sup>2</sup>Corrected by electronic flow characterization.

<sup>3</sup>Limited by user selected Deadband.

**ACTUATOR**

**Type:** Self-contained Electrohydraulic actuator, linear motion

**Materials of Construction:** Anodized aluminum (Electrohydraulic module), anodized aluminum and steel (cylinder)

**Environmental Rating:** NEMA 4X (STD)

CSA approved CI I, Div 2, Grps B, C & D

CSA approved CI I, Div 1, Grps B, C & D

**Ambient Temperature Range:** -5 °F (-20 °C) to +200 °F (93 °C), optional to 300 °F (150 °C). Lower temperature operation is possible with insulation and auxiliary heating.

*See TM19 - Temperature Guidelines*

**Motor:** Stepping type for B & C size power modules; servo type for ¼D, ½D and D size power module

**Oil:** Automotive Type, 5W-50

**Circuit:** Flow Match System - integral gear pump, valving (FMV), manifold and reservoir

**Heater:** Cartridge type, 150 watts, thermostat controlled

**ELECTRONICS**

**Contents:** Position Control Processor (PCP), motor driver, power supply and termination

**Environmental Rating:** NEMA 4X - steel (STD)

CSA approved CI I, Div 2, Grps B, C & D

CSA approved CI I, Div 1, Grps B, C & D

**Ambient Temperature Range<sup>1</sup>:**

B & C Module: -40 °F (-40 °C) to 140 °F (60 °C)

¼D, ½D & D Module: -40 °F (-40 °C) to 120 °F (49 °C)

**Failure Mode:** Selectable by user on loss of signal. Standard is fail in place on loss of power.

**Control Signal:**

Analog: 4-20 mA (STD), others available

Pulse: 24-120 volts, ac or dc

**PCP:** Contains 3 button keypad and 5 character LED display. Program stored in socketed EPROM and setup parameters stored in nonvolatile memory.

<sup>1</sup>Ambient temperature only. Direct solar heat load must be avoided.

**Type:** Integral with cylinder, rigidly connected to stem.

**Environmental Rating:** NEMA 4X (STD)

CSA approved CI I, Div 2, Grps B, C & D

CSA approved intrinsically safe (for Div 1 Actuator)

**Sensor:** Sealed thin film potentiometer (50x10<sup>6</sup> cycles)

**Transmitter:** 3 wire, resistance to current (4-20 mA)

**POWER REQUIREMENTS**

**Voltages:**

B module: 12 Vdc, 24 Vdc, 48 Vdc, 125 Vdc, 120 Vac (STD), 208 Vac, 220 Vac, 440 Vac

C module: 120 Vac (STD), 208 Vac, 220 Vac, 440 Vac

¼D module: 120 Vac (STD), 208 Vac, 220 Vac, 440 Vac

½D module: 120 Vac (STD), 208 Vac, 220 Vac, 440 Vac

D module: 120 Vac, 208 Vac, 220 Vac (STD), 440 Vac

**Consumption (Maximum):**

B module: 350 watts

C module: 700 watts

¼D module: 700 watts

½D module: 1 200 watts

D module: 2 000 watts

*Please refer to TM2 - Power Consumption*

**OPTIONS**

**Failure** (upon loss of power):

*Spring*, extend or retract - includes an integral solenoid latched to the electric power.

*Please refer to PM4 - Spring Failure*

*Accumulator* - REXA's unique self-charging and self-contained system.

*Please refer to PM21 - Accumulator System*

**Position Transmitter:** Provides 4 to 20 mA output proportional to position. Includes alarm indication.

*Please refer to PM12 - Position Transmitter*

**Booster Pump:** High speed operation in either direction.

Works in conjunction with a standard power module.

*Please refer to PM23 - Booster Pump Configuration*

**Enhanced Software:**

*0.05% Deadband* - increases the standard resolution.

*Minimum Control Point* - limits actuator operation in the potentially damaging zone near a valve seat.

*Two Speed* - Reduces actuator speed.

*Flow Characterization* - 11 point, 10 line segments.

*Please refer to PM18 - Advanced Control Options*

**Stem boot:** For environments where the seals may be damaged by airborne particles.

**Split Clamp:** Bolted connection between the stems of the actuator and driven device.

**Auxiliary Control:**

*External* - NEMA 4 switches and a window are installed on the cover of the control enclosure.

*Remote* - A manual control station may be located remotely.

*Please refer to PM17 - Auxiliary Control*

**Limit Switches:**

*Electrical* - Two relays, SPDT, switched by the PCP.

Includes alarm indication

*Mechanical* - Yoke mounted, 2 or 4, SPDT

*Please refer to PM13 - Limit Switches*

**Manual Override** (uses the normal hydraulic circuit):

*Handwheel/Drill Drive* - declutchable, attached to the outboard end of the motor.

*Geared (5:1) Hand Crank* - installs in place of the motor on a separate C module.

*Please refer to PM15 - Manual Override*

**Surge or Trip Control:** High speed operation in one direction to limit the effects of upset conditions.

*Please refer to PM20 - Surge Control*

**Electrical Transient:** The electronics and power supplies can be isolated to resist electrical damage. Highly recommended on remote installations.

REXA is continually improving the design of its products.  
 As such, specifications are subject to change.

Mechanical

Hydraulic

Control Enclosure

Feedback

*REXA is continually improving its products. Therefore, specifications are subject to change.*

REXA

Xpac

# Model Numbering System

## L Series Actuator

The model number provides a physical description of the mechanical portion of the actuator. The output thrust, power modules and failure mode are described in this simple system. The stroking rate specifies the maximum speed of operation for a particular actuator and power module combination.

### Model Number

Linear



Thrust lb	Stroke in inches
2000 to 120000	.75, 2, 4, 6, 8, 11, 16, 22
For complete list of thrusts, see below.	

- Power Modules**
- B: Single B
  - C: Single C
  - ¼D: Single ¼D
  - ½D: Single ½D
  - D: Single D
  - 2D: Two D Manifold
  - 2C: Two C Manifold
  - ½D,P9: Booster Pump
  - D,P40: Booster Pump

- Spring Fail Position  
(Upon Power Loss)**
- P: None - Lock in Place
  - E: Extend
  - R: Retract

*Example: L2000-2-B-P*  
A linear series Xpac actuator with 2000 lb thrust and B power module. Any stroke up to 2 inches. Fail in place upon loss of power. Stroke rate is 6 seconds per inch.

Thrust lb (N)	Stroke Rate (seconds per inch stroke)							
	Power Module							
	B	C/¼D	½D/2C	D	2D	½D,P9 <sup>2</sup>	D,P40 <sup>2</sup>	SF <sup>1</sup>
2000 (8896 N)	6	2	1	0.5	NA	NA	NA	0.6
4000 (17790 N)	12	4	2	1	.5	NA	NA	1
5000 (22240 N)	15	5	2.5	1.25	.6	.25	NA	1.25
10000 (44480 N)	30	10	5	2.5	1.25	.5	CF	2.5
15000 (66725 N)	NA	15	7.5	3.75	1.8	.75	CF	3.75
20000 (88965 N)	NA	20	10	5	2.5	1	.25	5
40000 (177928 N)	NA	NA	20	10	5	2	.5	10
60000 (266893 N)	NA	NA	NA	15	7.5	3	.75	16
80000 (355858 N)	NA	NA	NA	20	10	4	1	20
120000 (533760 N)	NA	NA	NA	NA	15	6	1.5	30

In most installations, these speeds may be reduced by a factor of four without affecting the rated output.  
<sup>1</sup>SF - Spring Failure. Estimated time is for the standard solenoid and spring. The actual times may vary based on spring force and temperature. Faster times are available.

<sup>2</sup>½D,P9 and D,P40. Booster pumps provide high speed operation, while maintaining our fine positioning capability.  
*Please refer to PM23 - Booster Pumps*

*Your Local Sales Representative is:*

*For More Information Contact:*

**Koso America, Inc.**

4 Manley Street

West Bridgewater, MA 02379

508-584-1199

Fax 508-584-2525